

XSP / XSR DMX Splitter & RDM Hub User Manual

XSP / XSR
DMX Splitter /RDM Hub
User Manual

Issue 5 (2010-11-30)

Copyright © 2010 SWISSON AG

No part of this documentation may be reproduced or transmitted in any form or by any means, electronic or mechanical, including photocopying and recording, without the prior written permission of SWISSON AG.

The information in this documentation is supplied without warranty of any kind, either directly or indirectly, and is subject to change without prior written notice. SWISSON its employees or appointed representatives will not be held responsible for any damages to software, hardware, or data, arising as a direct or indirect result of the product(s) mentioned herein.

Dieses Dokument darf weder vollständig noch auszugsweise in irgendwelcher Form reproduziert, kopiert oder gespeichert werden, ohne das vorherige schriftliche Einverständnis der Firma SWISSON AG.

Die Informationen in diesem Dokument sind ohne jegliche Gewähr und können ohne vorherige Ankündigung jederzeit im Sinne des technischen Fortschritts geändert werden. SWISSON und seine Angestellten oder seine Vertreter sind nicht verantwortlich für Schäden, welche direkt oder indirekt mit den in diesem Dokument beschriebenen Geräten entstanden sind.

Issued by

SWISSON AG
Fabrikstrasse 21
CH-3250 Lyss
Switzerland

SWISSON of AMERICA Corp.
2419 East Harbor Blvd. #34
Ventura, CA 93001
U.S.A.

E-Mail: welcome@swisson.com

XSR and XSP

DMX Splitter/Booster & RDM Hub

Introduction

The XSR and XSP series of RDM hubs and DMX splitter/boosters from SWISSON can be easily and economically integrated into any lighting system where you wish to split and boost DMX and RDM signals.

While the XSP splits and boost only DMX signals, the XSR also detects RDM data and uses its bidirectional functionality to report back to the controller (Lighting Board).

All output ports on both XSP and XSR are optically isolated. A strong power supply allows a reliable operation in a wide voltage range. A large program of XSR and XSP devices is available; consisting of different housings, different connector types and different numbers of input and output ports.

Applications

- Concert Lighting
- Live Events
- Multimedia Shows
- Theater
- TV Sets
- Theme Parks
- Achitectoral Lighting

Typical Application

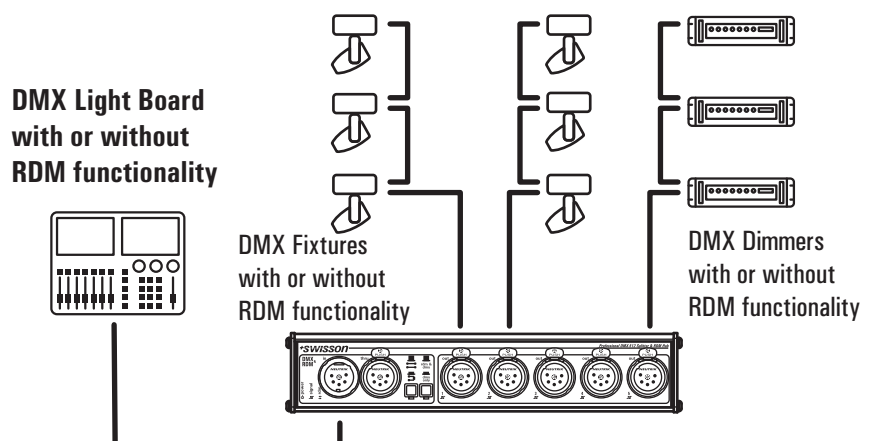

The XSR works within DMX / RDM environments and works as well as in pure DMX environments. The XSR is a good solution for those who expect to use RDM in future, because the XSR acts as a normal DMX splitter if there is no RDM data. The XSP work only within DMX environments.

Unpacking

The DMX Splitter is packaged in a cardboard box. The following items are included:

- The Device
- This user manual

Safety Information

Consider the following notes absolutely when you set up, connect and use the XSP / XSR.

This product is not for household use. Read this manual before operating the device, follow the safety precautions and observe all warnings in this manual.

Use this device only in accordance with local laws and regulations.

Safety precautions

- Disconnect the device from AC power before removing any cover or part, including fuse and when not in use.
- Ensure that the device is electrically connected to ground (earth).
- Use only a source of AC power that complies with local building and electrical codes and has both overload and ground-fault (earth fault) protection.
- Connect the Devices to AC power using the supplied power cable.
- Before using the device, check that the power distribution equipment and cables are in perfect condition and rated for the current required of all connected devices.
- Isolate the device from power immediately if the power cable or power plug in any way damaged, defective or wet, or if they show signs of overheating.
- Do not expose the device to rain or moisture.
- Do not operate the device if any cover or component is missing damaged or deformed.
- Refer any service operation not described in this manual to Swisson.
- Provide unrestricted airflow around the device
- Do not operate the device if the ambient temperature exceeds 55°C (131°F)
- Do not modify the device in any way not described in this manual or install other than genuine Swisson parts.
- Do not attempt to bypass fuse. Replace defective fuse with one of the specified type and rating only.
- When suspending the device, ensure that the supporting structure and all hardware used can hold at least 10 times the weight of all devices suspended from them.
- Install as described in this manual a secondary attachment such as a safety cable that is approved by an official body such as TÜV as a safety attachment for the total weight it secures. The safety cable must comply with EN 60598-2-17 Section 17.6.6 and be capable of bearing a static suspended load 10 times the weight of the device.
- Check all external covers and rigging hardware are securely fastened.
- Block access below the work from a stable platform whenever installing, servicing or moving an overhead device.
- Do not use the device in areas where it is exposed to direct sunlight.
- Do not use the device in areas that are considered to be 'highly combustible'.

Benefits using a XSP/XSR Splitter / Booster

Boost

On installations with excessively long cable runs the DMX and/or RDM signal can be compromised or significantly weakened by the distance.

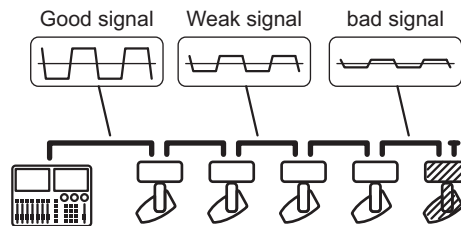

The XSP/XSR boosts the signals thus eliminating signal interference

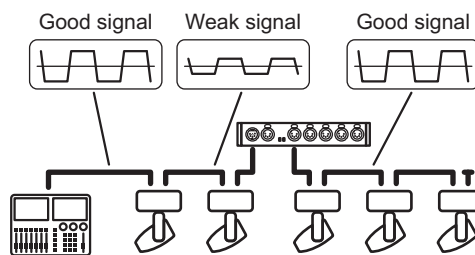

Regenerate

In harsh environments DMX and RDM signals can be disturbed or corrupted.

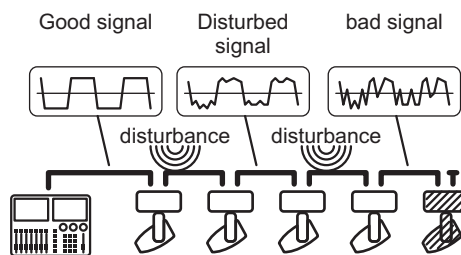

The XSP/XSR cleans and regenerates the signals.

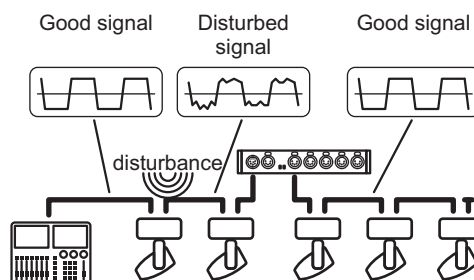

Split

A simple split of signal lines is not allowed. The bidirectional operation of RDM is even more sensitive to the split on that than DMX.

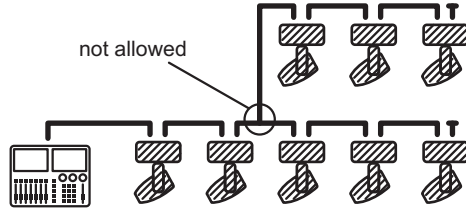

A split of the signal lines is possible with the XSR / XSP by using different output ports

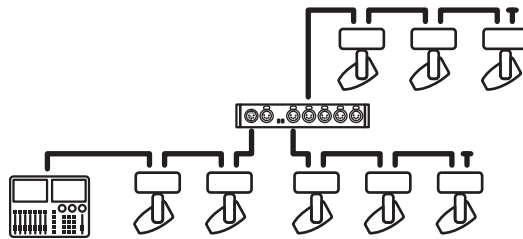

Reduces reflection problems

Signal reflection is a common problem on large DMX installations or on long signal lines. The bidirectional operation of RDM is more sensitive to reflections than DMX.

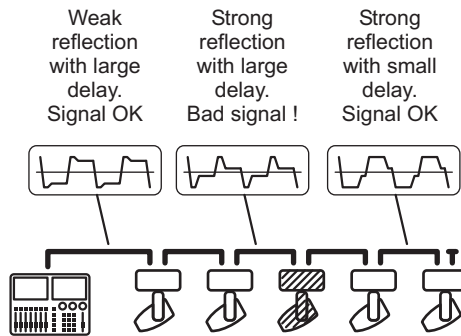

The XSP/XSR split the line into smaller segments with a regenerated signal, which reduces the delay of the reflection on each segment.

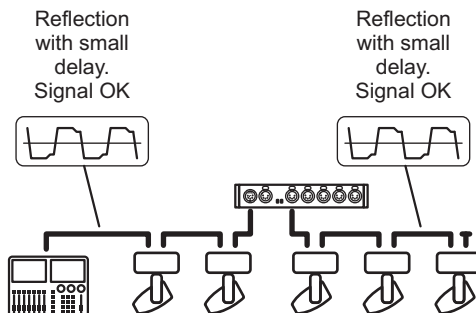

Protect

In case of an over voltage on the DMX and RDM line(s), all devices on that line can be damaged.

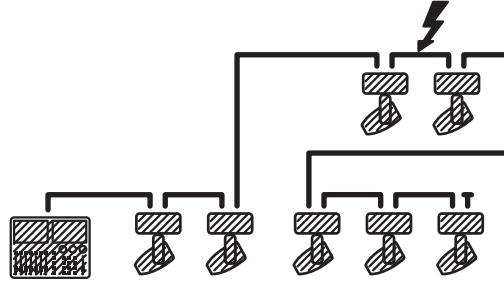

The XSP/XSR separate the line into multiple segments. The over voltage is restricted to the concerned segment. The XSP/XSR itself is well protected against transient over voltage and the optical isolation of each port prevents a damage of other ports and segments in case of a permanent over voltage.

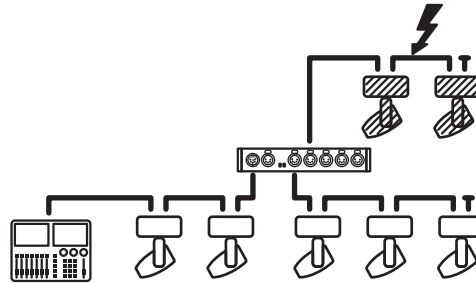

XSP Block Diagram

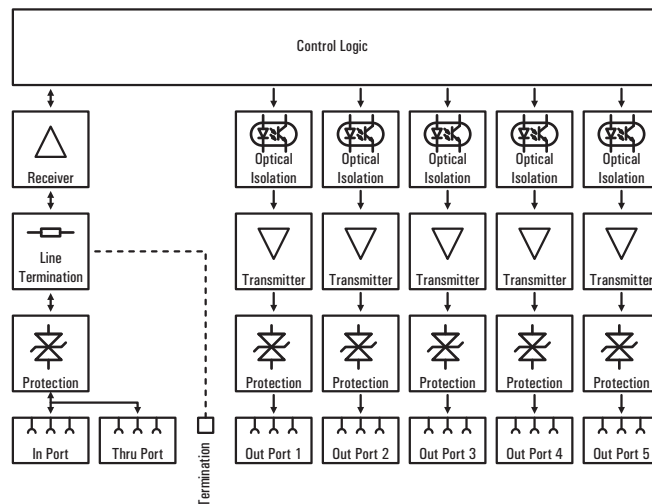

XSR Block Diagram

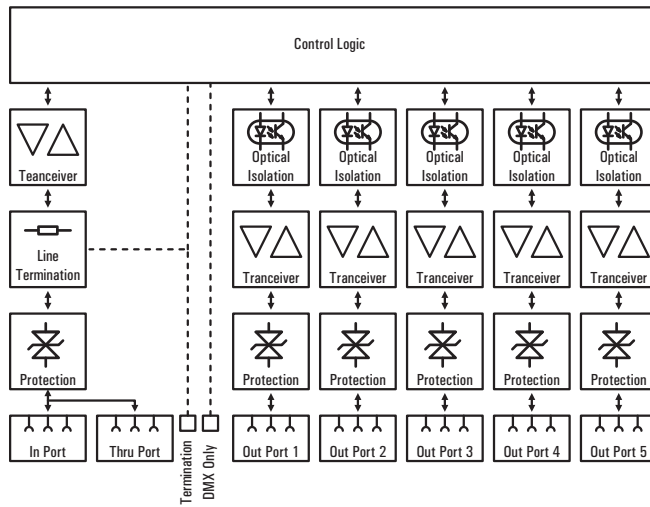

Mains Connection

Two different mains connections are available:

The US versions are delivered by Swisson with a "Edison Plug" (NEMA-5-15). These models has a "-US" suffix at the end

The International versions are delivered without any plug. *Swisson distributors or dealers may deliver the devices with a country specific plug.*

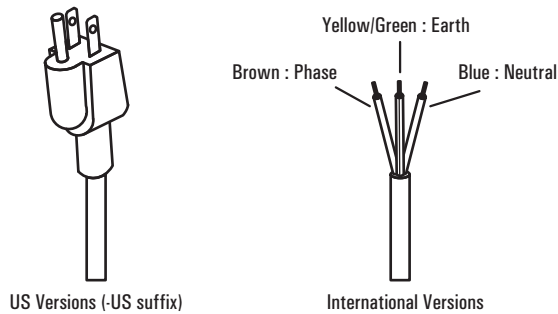

	Wire (US System)	Wire (EU System)	Symbol
Live	black	brown	L
Neutral	white	blue	N
Ground (Earth)	green	yellow/green	⏏ or ⏚



Consult a qualified electrician if you have any doubts about proper installation.

The socket where the device is plugged in must be close to the device and easily accessible.



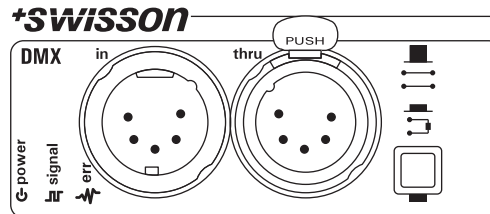

Input Section XSP Versions

The Input section of the versions with XLR connectors



The Input section of the versions with terminals:
The "input" and "thru" terminals are at the rear of the device.



-  The Power LED shows if the device powered and if power supply unit of the XSP is working
-  A green LED shows if a signal is available at the Input port.
-  A red LED shows if the received signal is faulty
-  The XSP has a built in line termination. This can be activated by pressing the termination button. A LED shows if the termination is activated.

Input Section XSR Versions

The Input section of the XSR versions with XLR connectors

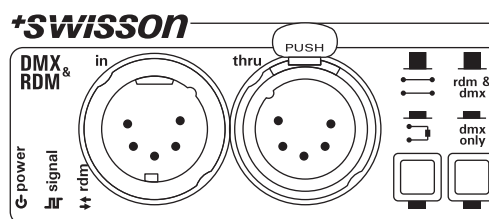

The Input section of the XSR versions with terminals:
The "input" and "thru" terminals are at the rear of the device.



G-power

The Power LED shows if the device powered and if the power supply unit of the XSR is working

signal

A multicolor LED shows if a signal is available at the Input port. The LED has 2 different states:

Green: Signal is present and Ok

Red: No signal present or Signal is present but faulty

rdm

The RDM LED show if RDM data packets are preset. In a pure DMX environment this LED remains off.



The XSR has a built in line termination. This can be activated by pressing the termination button. A LED shows if the termination is activated.

dmX only

The "dmX only" function of the XSR allows removal off all RDM data from the output ports. A LED shows if the "dmX only" function is activated.

RDM Identify

Blinking of all output LEDs: The RMD Identify is activated.

Errors

Blinking of DMX only LED: Error UID not valid. RDM operation is not possible. DMX operation only.

Blinking of all LEDs (except power and termination LED): Fatal error

Input and Thru Port

The THRU port is hardwired with the INPUT port and allows to daisy-chain the devices even when the XSR is not powered. On all XSP and XSR models with 5-Pin XLR connector the pin 4 and 5 are also looped thru to the THRU port. On all other models pin 4 & 5 are not available.

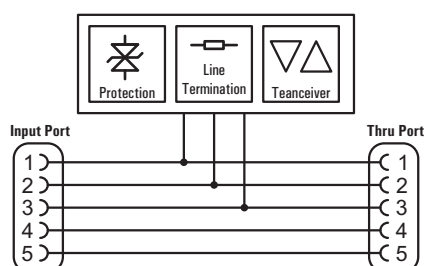

Line Termination

All XSP and XSR splitters have a built-in line termination. The termination is activated by pressing the termination button. On terminal and Installation version the button is only accessible with a tool (such as a paper clip).

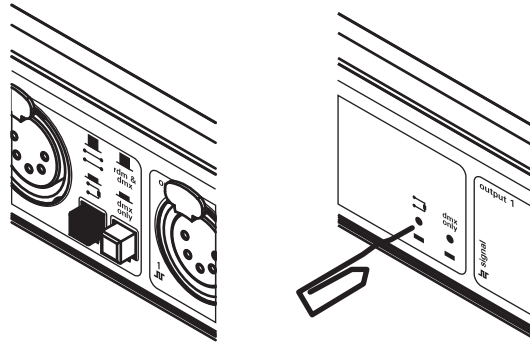

DMX Only (only on XSR models)

The "DMX only" function removes all non DMX data before forwarding the data to the output ports. RDM data will be removed too. This can be helpful when DMX devices are not compatible and do not check the data they receive as valid DMX.

The "DMX only" function is activated by pressing the "DMX only" button. On terminal and Installation version the button is only accessible with a tool.

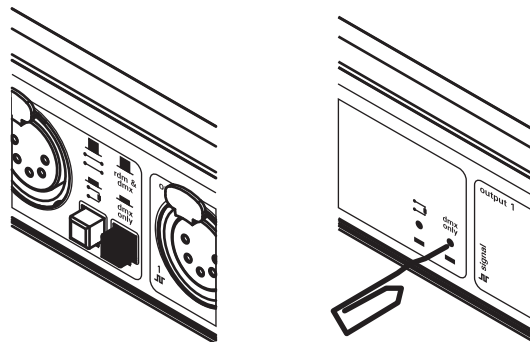

Output Ports

The output section of the versions with XLR connectors:

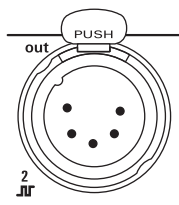

The OUTPUT section of the versions with terminals:

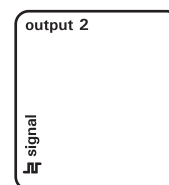

The OUTPUT terminals are at the rear of the devices.

Each output port is individually optically isolated, meaning that it is totally isolated from the other output ports and the input selection. The Pins 4&5 on the models with 5-Pin XLR connectors are not connected.

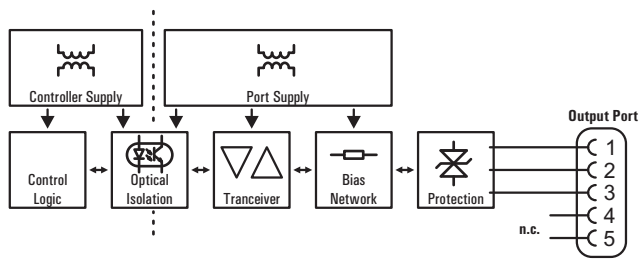

signal
IF

On the XSR the signal LED of the OUTPUT ports show if a valid signal is transmitted. It works bidirectionally:

When sending DMX or RDM packets and when receiving RDM responses.

This LED is not available on the XSP models.

XSP / XSR Box Models

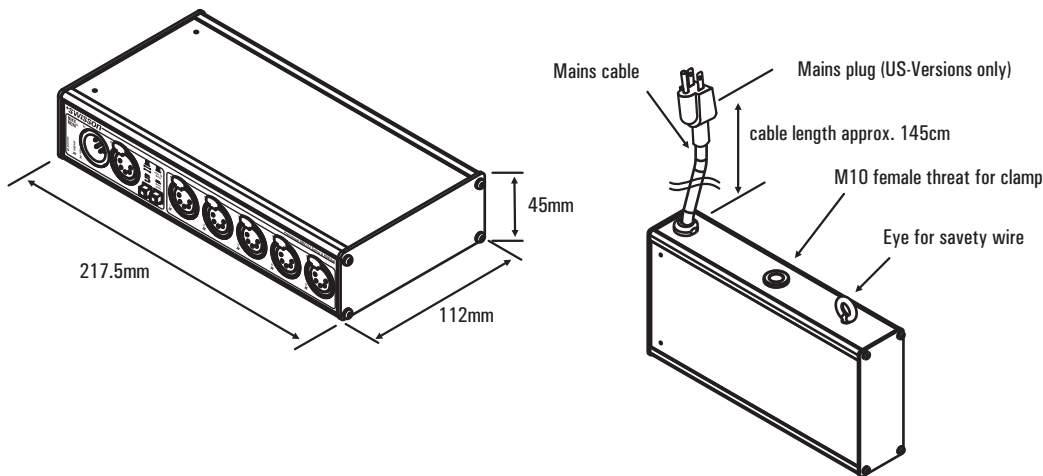

The length of the M10 screw which enters the XSP/XSR should not exceed a maximum of 20mm.

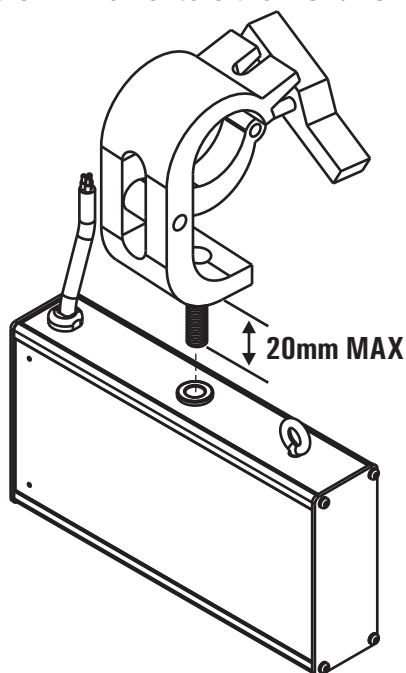

Clamp is not included with the XSP/XSR.

Single Rack Models

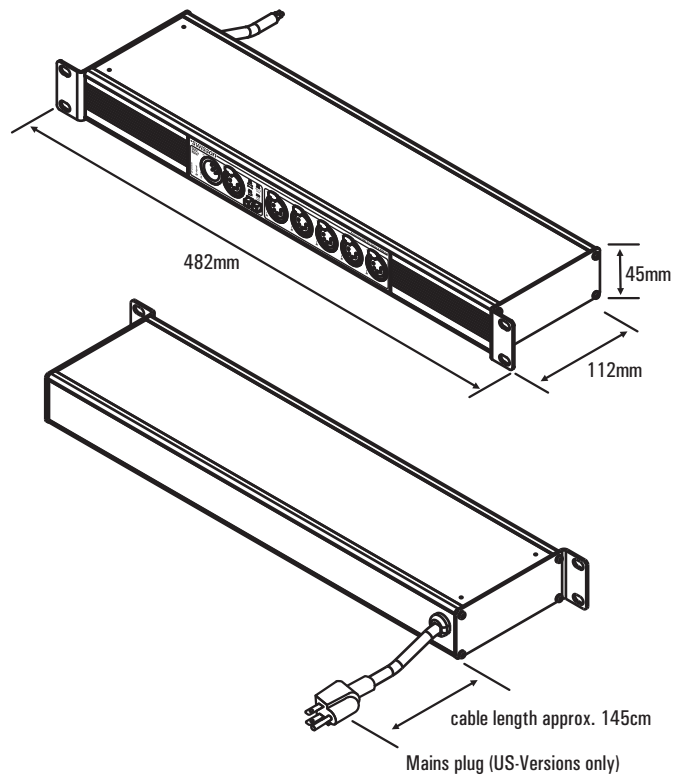

Double Rack Models

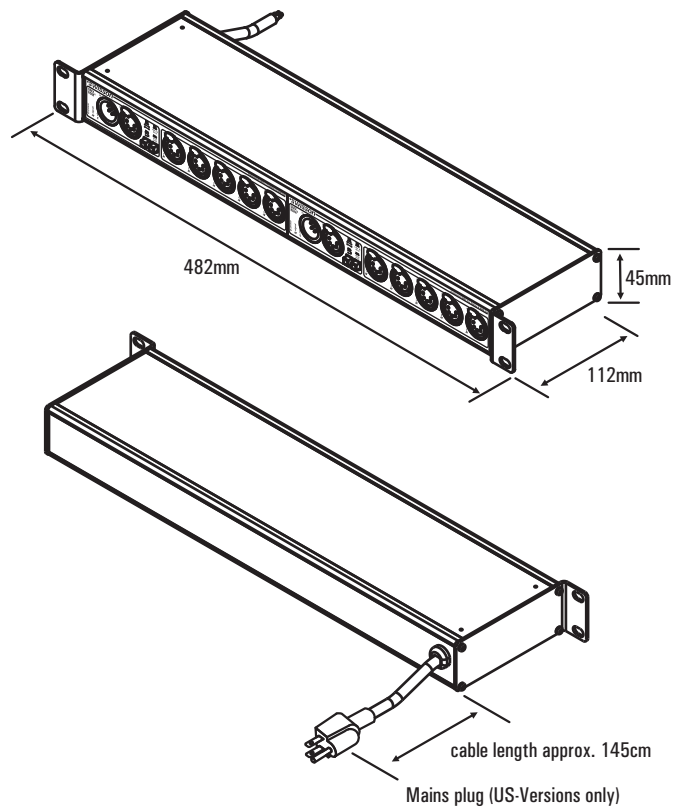

Single Rack Terminal Models

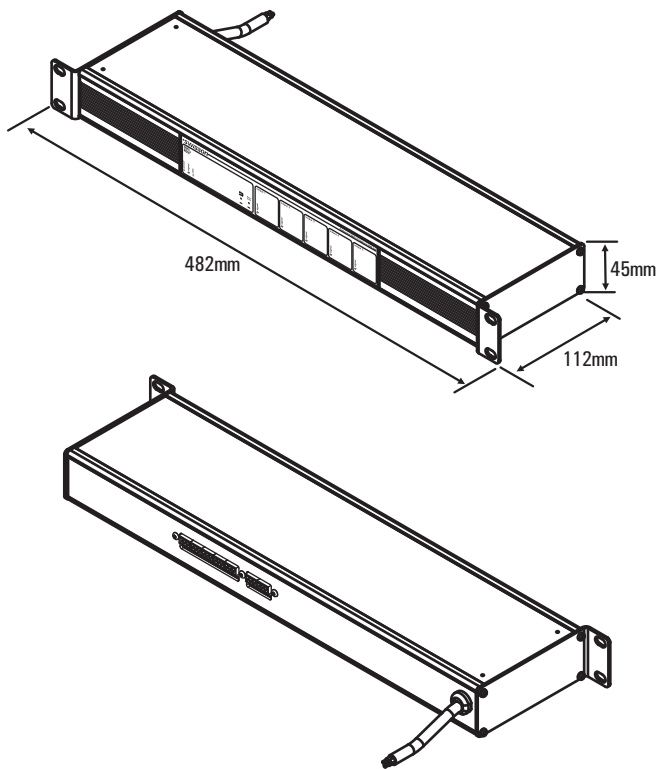

Double Rack Terminal Models

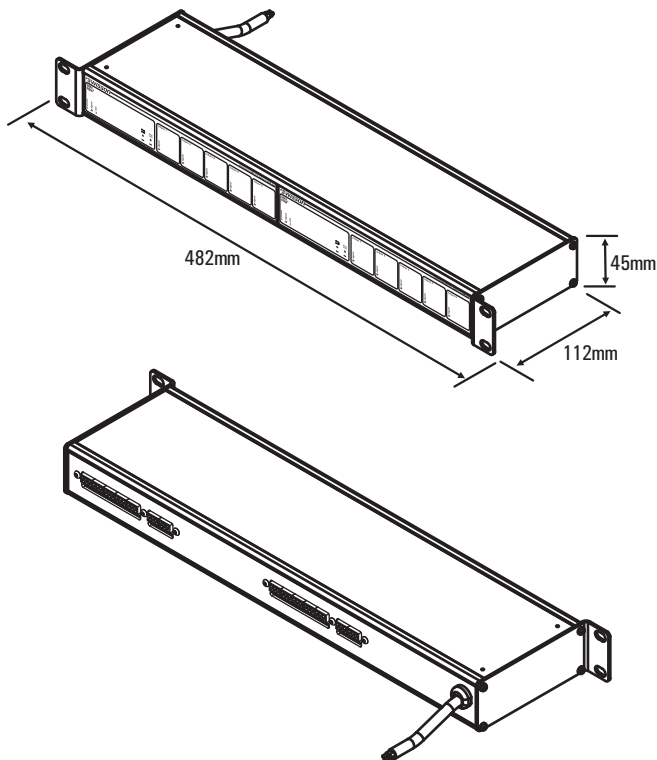

Terminal Models

The terminal models of the XSP/XSR comes with pluggable terminal blocks. The terminal blocks are located at the rear of the device.

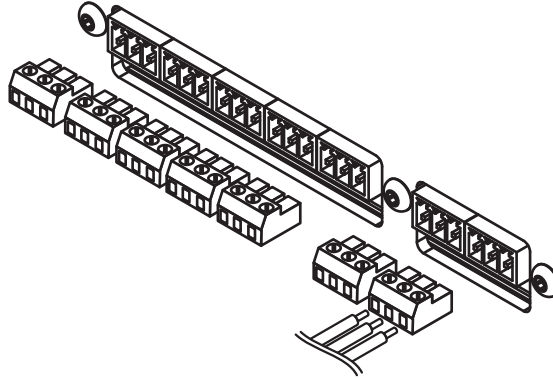

XSP/XSR terminal models are shipped with the terminal blocks. They can accept wires up to AWG 17 (~1mm²)

Installation model

The XSP/XSR installation model is made to be installed by certified professionals. This version has no plugs. All connections are located inside of the device.

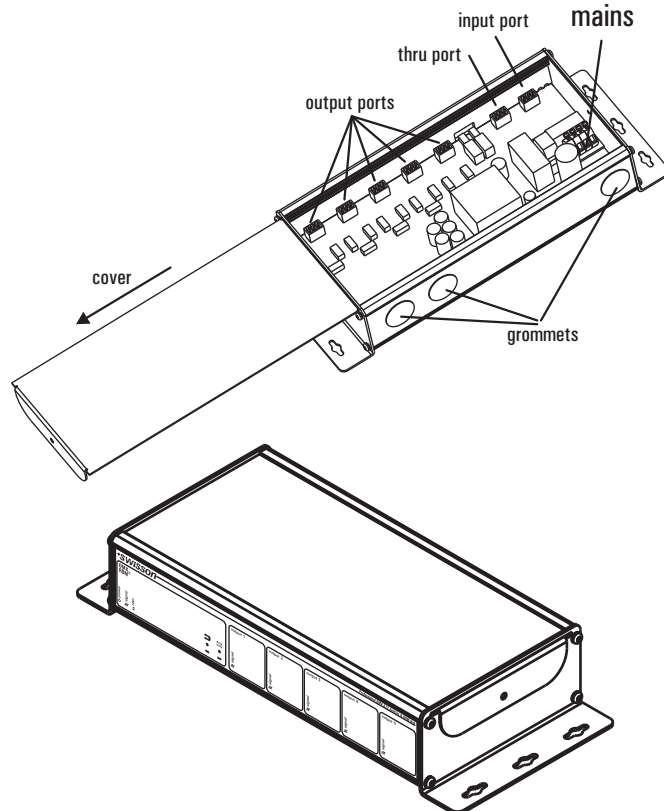

XSP standard program

-
- | | |
|----------|----------------------------|
| 10 11 63 | XSP-3B |
| 11 11 63 | XSP-3B-US (with NEMA 5-15) |

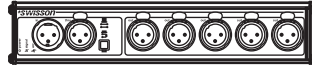

Front view

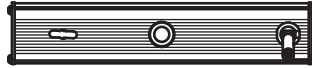

Rear view

-
- | | |
|----------|----------------------------|
| 10 11 74 | XSP-3R |
| 11 11 74 | XSP-3R-US (with NEMA 5-15) |

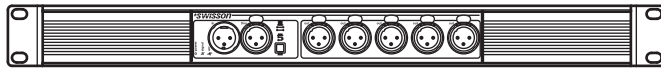

Front view

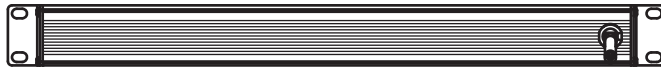

Rear view

-
- | | |
|----------|-------------------------------|
| 10 11 85 | XSP-3R-3R |
| 11 11 85 | XSP-3R-3R-US (with NEMA 5-15) |

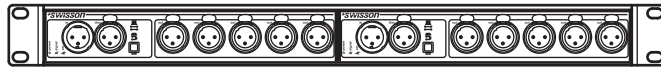

Front view

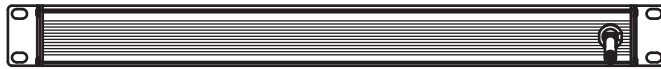

Rear view

-
- | | |
|----------|----------------------------|
| 10 11 62 | XSP-5B |
| 11 11 62 | XSP-5B-US (with NEMA 5-15) |



Front view

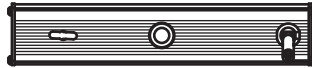

Rear view

-
- | | |
|----------|----------------------------|
| 10 11 72 | XSP-5R |
| 11 11 72 | XSP-5R-US (with NEMA 5-15) |



Front view



Rear view

-
- | | |
|----------|-------------------------------|
| 10 11 82 | XSP-5R-5R |
| 11 11 82 | XSP-5R-5R-US (with NEMA 5-15) |



Front view



Rear view

10 11 60 XSP-5B5
11 11 60 XSP-5B5-US (with NEMA 5-15)

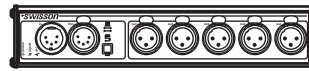

Front view

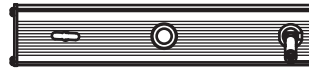

Rear view

10 11 70 XSP-5R5
11 11 70 XSP-5R5-US (with NEMA 5-15)

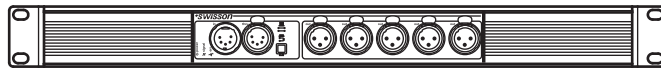

Front view



Rear view

10 11 80 XSP-5R5-5R5
11 11 80 XSP-5R5-5R5-US (with NEMA 5-15)



Front view



Rear view

10 11 87 XSP-5R2-5R2
11 11 87 XSP-5R2-5R2-US (with NEMA 5-15)



Front view



Rear view

10 11 84 XSP-5R-5R5
11 11 84 XSP-5R-5R5-US (with NEMA 5-15)



Front view



Rear view

10 11 86 XSP-5R-3R
11 11 86 XSP-5R-3R-US (with NEMA 5-15)



Front view



Rear view

10 11 50 XSP-TR5
 11 11 50 XSP-TR5-US (with NEMA 5-15)

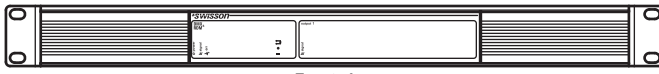

Front view

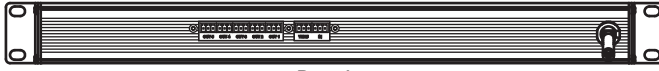

Rear view

10 11 51 XSP-TR5-TR5
 11 11 51 XSP-TR5-TR5-US (with NEMA 5-15)

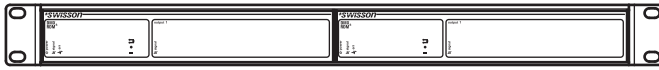

Front view

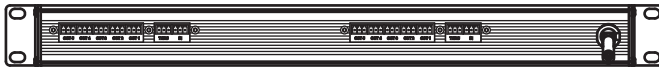

Rear view

10 11 98 XSP-IB5-W

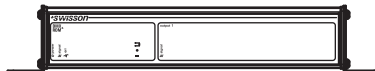

Front view

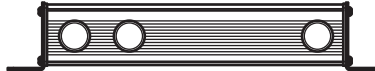

Rear view

XSR standard program

10 12 10 XSR-3B
 11 12 10 XSR-3B-US (with NEMA 5-15)



Front view

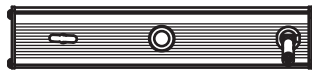

Rear view

10 12 20 XSR-3R
 11 12 20 XSR-3R-US (with NEMA 5-15)



Front view



Rear view

10 12 30 XSR-3R-3R
 11 12 30 XSR-3R-3R-US (with NEMA 5-15)



Front view



Rear view

10 12 11 XSR-5B
 11 12 11 XSR-5B-US (with NEMA 5-15)

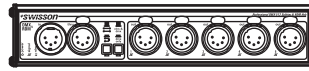

Front view

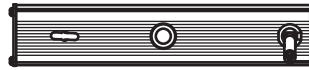

Rear view

10 12 21 XSR-5R
 11 12 21 XSR-5R-US (with NEMA 5-15)



Front view

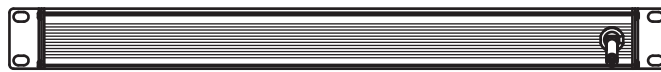

Rear view

10 12 31 XSR-5R-5R
 11 12 31 XSR-5R-5R-US (with NEMA 5-15)



Front view

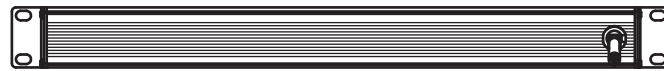

Rear view

10 12 16 XSR-5B5
 11 12 16 XSR-5B5-US (with NEMA 5-15)

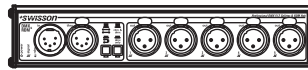

Front view

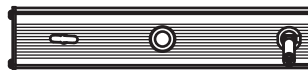

Rear view

10 12 26 XSR-5R5
 11 12 26 XSR-5R5-US (with NEMA 5-15)



Front view

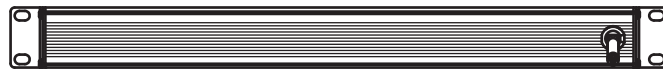

Rear view

10 12 33 XSR-5R5-5R5
 11 12 33 XSR-5R5-5R5-US (with NEMA 5-15)



Front view



Rear view

10 12 35 XSR-5R2-5R2
 11 12 35 XSR-5R2-5R2-US (with NEMA 5-15)



Front view

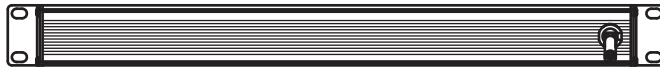

Rear view

10 12 34 XSR-5R-5R5
 11 12 34 XSR-5R-5R5-US (with NEMA 5-15)



Front view

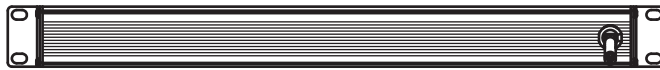

Rear view

10 12 32 XSR-5R-3R
 11 12 32 XSR-5R-3R-US (with NEMA 5-15)



Front view



Rear view

10 12 50 XSR-TR5
 11 12 50 XSR-TR5-US (with NEMA 5-15)



Front view

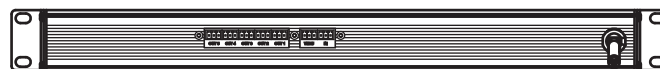

Rear view

10 12 51 XSR-TR5-TR5
 11 12 51 XSR-TR5-TR5-US (with NEMA 5-15)



Front view



Rear view

10 12 51 XSR-IB5-W



Front view

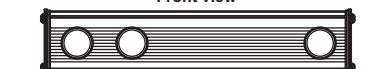

Rear view

Technical Data

Mains Voltage	100 - 240 [VAC]
Main Frequency	50/60 [Hz]
Current Consumption Single Units	0.2 [A]
Current Consumption Double Units	0.4 [A]
Operating Temperature	0F to 131F (-17°C to 55°C)
Protocol Standard	ANSI E1.11 (DMX-512) ANSI E1.20 (RDM)
Safety Standards	EN60950-1 UL508
EMC emission	EN55103-1
EMC immunity	EN55103-2

